



**Dr. Balasaheb Sawant Konkan Krishi Vidyapeeth
Dapoli**

e-Tender 4 Form

**Construction of customized high-rise metal
(GI) polyhouse for research purposes.**

All India Coordinated Research Project on Plastic
Engineering in Agriculture Structure and
Environment Management (PEASEM),

College of Agricultural Engineering and Technology,
DBSKKV Dapoli, MS, India,
Pin: 415712

Email: aicrp.petdapoli@gmail.com



**COLLEGE OF AGRICULTURAL ENGINEERING AND TECHNOLOGY,
DR. BALASAHEB SAWANT KONKAN KRISHI VIDYAPEETH,
Dapoli 415 712, Dist. Ratnagiri (MAHARASHTRA)
Phone No. (02358) 282414; Fax. (02358) 282414
Email: aicrp.petdapoli@gmail.com**



No. CAET/AICRP-PEASEM/e-Tender/ 391 /2021

Date: 5 MAR 2021

e-TENDER NOTICE NO. 4

Sealed tenders in the prescribed form are invited (in e-Tendering format only) in "D form" (that is in two envelope system) for "Construction of customized high-rise metal (GI) polyhouse for research purposes" from the registered manufacturers by the Associate Dean, College of Agricultural Engineering and Technology, Dr.B.S.K.K.V., Dapoli on or before 16/03/2021 (upto 11 pm). The tender form can be downloaded online but the form cost Rs.2800/- (Non Refundable), which can be paid online using e-tendering system. The tender forms will not be supply through post. The sealed tenders are proposed to be opened on 18/03/2021 (at 11.01 am). The brief details of the work, EMD details and cost for the tender form are as follows.

Sr. No.	Particulars	Amount of E.M.D. in Rs.	Period of completion	Tender form fee (Non-refundable)
1	Construction of customized high-rise metal (GI) polyhouse for research purposes.	Rs.14000/-	Maximum two months from the order date	Rs.2800/- per set

The rates shall be quote for Dapoli as destination and including the all taxes, transportation, material, erection, testing etc. (i.e **everything, on turn key basis**) considering the detailed specifications given in Appendix-II (**Appendix III along with figures 1 and 2**). No extra payment will be made on any ground thereafter. The e-Tender form will be only considered/opened if all the technical documents be attached with the tender. **Any type of exemption for EMD will not be accepted by this University.** Also, in case of successful bidder, 3% (including EMD amount) of the final order amount will be withheld as 'Security Deposit' for the period of 1 year i.e. (**One year complete warranty on polyhouse frame, all joints, curtain rolling systems and inside shade net sliding system**). **The University reserves all the right to accept work or not to accept work.** All other details are included in the tender form, which is also available on the University website www.dbskkv.org

Associate Dean

College of Agricultural Engineering and
Technology, Dr. B.S.Konkan Krishi Vidyapeeth,
Tal. Dapoli, Dist. Ratnagiri. (M.S.)

Place: Dapoli

Date: 5/3/2021



**COLLEGE OF AGRICULTURAL ENGINEERING AND TECHNOLOGY,
DR. BALASAHEB SAWANT KONKAN KRISHI VIDYAPEETH**
Dapoli 415712, Dist. Ratnagiri (MAHARASHTRA)
Phone No. (02358) 282414; Fax. (02358) 282414
Email: aicrp.petdapoli@gmail.com



No. CAET/ AICRP-PEASEM/e-Tender/ 391 /2021

Date: 5 MAR 2021

e-TENDER NOTICE NO. 4

Sealed tenders in the prescribed form are invited (in e-tendering format only) in “D form” (that is in two envelope system) for “Construction of customized high-rise metal (GI) polyhouse for research purposes” from the registered manufacturers by the Associate Dean, College of Agricultural Engineering and Technology, Dr.B.S.K.K.V., Dapoli.

Sr. No.	Particulars	Amount of E.M.D. (Rs.)	Period of completion	Tender form fee (Non-refundable)
1	Construction of customized high-rise metal (GI) polyhouse for research purposes.	Rs.14000/-	2 Months (Maximum)	Rs.2800/- per set

e-TENDER 4 SCHEDULE

Sr. No	Procedure for Dr. Balasaheb Sawant Konkarni Agricultural University	Procedure for Contractor/ Vendor	Start Date and Time	Expiry Date and Time	Envelope Remarks
1	Release e-Tender	-	05-03-2021 Time 10:00	-	-
2	-	e-Tender download	05-03-2021 Time 10:00	16-03-2021 Time 23.00	Submission of Technical (T1) and Commercial (C1) envelope
3	-	e-Tender preparation	05-03-2021 Time 10:00	16-03-2021 Time 23.00	Submission of Technical (T1) and Commercial (C1) envelope
4	Close for Technical Bid	-	16-03-2021 Time 23.01	16-03-2021 Time 23.55	Technical (T1) envelope submission will be closed.
5	Close for Price Bid	-	16-03-2021 Time 23.01	16-03-2021 Time 23.55	Commercial (C1) envelope submission will be closed.
6	-	Online submission of e-Tender	16-03-2021 Time 23:56	18-03-2021 Time 11.00	Final submission of tender (<u>Payment of service provider</u>)
7	Technical Bid Opening (If possible/Time may vary)	-	18-03-2021 Time 11.01	18-03-2021 Time 17:30	Technical (T1) envelope will be opened.
8	Price Bid Opening (If possible/Time may vary)	-	18-03-2021 Time 11.01	18-03-2021 Time 17:30	Commercial (C1) envelope will be opened.

Note: Please do enquiry regarding the date of opening of technical and price bid, in the office of Associate Dean, College of Agricultural Engineering and Technology, Dr. Balasaheb Sawant Konkan Agricultural University, Dapoli, District- Ratnagiri. Email enquiry will be preferred on: aicrp.petdapoli@gmail.com

General Terms and Conditions

1. When submitting the e-tender documents to the government website, there is need to submit scanned copies of following documents on the website:
 1. Registration Certificate of a firm / company.
 2. Certificate of manufacturer (self signed declaration on company's letter head) of polyhouses.
 3. GST certificate / number.
 4. Last three years (2019-20, 2018-19 & 2017-18) income tax return certificates for old firm / company. In case of new firm, last one year (2019-20) income tax return certificate is **must**.
 5. PAN card of the proprietor / company.
 6. Certificate of previous works / client's list (self signed on company's letter head).
2. As per Government policy, the e-tender documents are going to submit online only hence, there is **no need** to resubmit e-tender documents to the office by post.
3. The documents in the technical bid (**Envelope T1**) will be confirmed only after verifying the original documents, in case of any doubt about the documents. The tenderer's price bid (**Envelope C1**) will not be opened in case of technical documents and other verifications are found to be unsatisfactory and this will not be reported individually to such tenderers. Also, in this matter the decision of the committee of the university will be final and binding on the tenderer.
4. The e-tender form fee for this work is to be paid online before downloading, the e-tender form as well as the EMD amount is to be paid online only. The supplier has to pay all the amount online only. There will not be any concession or discount on e-tender form fee / EMD amount / security deposit. Also, any type of amount is not to be pay directly to any university account through the bank. It means, all the transactions are to be done through debit or credit card. There is need to pay e-tender form fee and EMD amount by considering the bank commission and other bank charges.
5. All eligible / interested tenderers are need to register at the main website, maharashtraetenders.in or adf.maharashtra.etenders.in/common/home.asp or <https://mahatenders.gov.in> of the e-Tender system, to download the tender and participate in the tender process. The suppliers involved in the e-Tender process should have to pay amount of **Rs. 1092 / - (One thousand ninety two only)** per e-tender for preparation of e-tender. This amount is required to be paid online by the tenderer during the period of e-tender Decryption/Re-encryption.
6. All the details of the tender notice are available from **05/03/2021** on the University website: www.dbskkv.org, also available on <https://mahatenders.gov.in> or <https://maharashtra.etenders.in>
7. Tenderers can contact the following telephone number if they have any doubts / issues regarding submission of tender, online certificates and delivery of digital certificates: Sify Technologies Ltd./Nextenders, Helpdesk Support: **9356492848, 9356468309, 7506797596**
Email: support.gom@nextenders.com
8. If the holiday is declared on the date of opening of the tender, the working of that particular day will be carried out on the next working day.
9. The manufacturer whose tender will be accepted, has to accept warranty conditions in the prescribed format on the bond paper of **Rs. 100/-**.
10. **Other terms and conditions will be available in the e-tender form. The signed authority reserves the right to reject any tender or all tenders at any stage without giving any reason.**
11. Since the works in the tender are time bound, the tenderer will be obliged to complete the work within the prescribed timeframe from the date of issue of confirmed order. The Associate Dean,

College of Agricultural Engineering and Technology, Dapoli reserves all the rights about giving extension for completion of the work in the situations deemed appropriate.

12. **There is need to provide tax invoice including work completion duration, warranty, guaranty, transportation, installation at the destination (DBSKKV Dapoli).**
13. For the more information, the tenderer can contact to the office of the Associate Dean, College of Agricultural Engineering and Technology, Dr. Balasaheb Sawant Konkan Agricultural University, Dapoli, District Ratnagiri; during the working hours (9 am to 5.30 pm)
14. **3 % security deposit** amount will be charged from the successful tenderer. The amount will be adjusted through the EMD amount. Also, the security deposit will be returned after the warranty period and the supplier must surrender the original receipt while asking for the refund of the security deposit.

O/C
y

Associate Dean
College of Agricultural Engineering and
Technology, Dr. B.S.Konkan Krishi Vidyapeeth,
Tal. Dapoli, Dist. Ratnagiri. (M.S.)

Place: Dapoli

Date: 5 MAR 2021

CC (By email):

1. Hon. Director General, Maharashtra Krishi Shikshan Parishad, Survey No. 132 / B, Bambara, Bhosalenagar, Pune.
2. The Registrar, Dr. Balasaheb Sawant Konkan Agricultural University, Dapoli with request to circulate e-Tender notification among all EC members of DBSKKV Dapoli by email.
3. AKMU, Dr. Balasaheb Sawant Konkan Agricultural University, Dapoli with request to upload e-Tender notification on the university website with immediate effect and keep it upto last date (16/03/2021 upto 23.00) of tender submission.



**COLLEGE OF AGRICULTURAL ENGINEERING AND TECHNOLOGY,
DR. BALASAHEB SAWANT KONKAN KRISHI VIDYAPEETH**

Dapoli 415712, Dist Ratnagiri (MAHARASHTRA)
Phone No. (02358) 282414, Fax (02358) 282414



Tender for “Construction of customized high-rise metal (GI) polyhouse for research purposes”

by

**Associate Dean,
College of Agricultural Engineering and Technology,
Dr. B.S.Konkan Krishi Vidyapeeth,
Tal. Dapoli, Dist. Ratnagiri. (M.S.)**

**Phone No. (02358) 282414 Fax. (02358) 282414
Email: aicrp.petdapoli@gmail.com**

Summary

1.	Date of issue of tender form	:	05/03/2021
2.	Last date for receipt of sealed tender	:	16/03/2021 (upto 11 pm)
3.	Date of opening of tenders	:	18/03/2021 (at 11.01 am)
4.	Cost of tender form	:	Rs. 2800/- per set (Non-refundable)
5.	Earnest Money Deposit (EMD)	:	Rs. 14000 /-



COLLEGE OF AGRICULTURAL ENGINEERING AND TECHNOLOGY,

DR. BALASAHEB SAWANT KONKAN KRISHI VIDYAPEETH

Dapoli 415712, Dist. Ratnagiri (MAHARASHTRA)

Phone No. (02358) 282414; Fax. (02358) 282414

Email: aicrp.petdapoli@gmail.com



Tender for "Construction of customized high-rise metal (GI) polyhouse for research purposes".

FORM OF TENDER

To,

The Associate Dean,
College of Agricultural Engineering and Technology,
Dr. B. S. Konkan Krishi Vidyapeeth,
Dapoli.

Dear Sir,

1. In response to the tender notice published in the daily newspaper _____, dated the _____, University website www.dbskkv.org, I/We submit herewith the tender form for Supply of
2. I/We have thoroughly examined and understood the terms and conditions of the tender contained in Appendix-I (Part I) and I/We agree to abide by them in full.
3. **I/We offer to undertake the Construction of customized high-rise metal (GI) polyhouse and have quoted the rates inclusive of all taxes, transportation, material, erection, testing etc. (i.e. everything on turn key basis)** for destination as given in Appendix II. It is agreed that, there is no additional charges other than those mentioned in word (in the bid form or Appendix-II) payable to me/us.
4. I/We accept that the rates offered shall remain valid for **a period of three months** from the date of execution of agreement. I/We further agree that if the date upto which the offer would remain open be declared as holiday for office, then offer will remain open for acceptance till next working day.
5. I/We shall be bound by communication of acceptance of the offer, dispatched within prescribed time.
6. **I/We accept that the right to accept or reject whole or part of the tender without assigning any reason is reserved with the University. The decision of the University will be final and shall be binding on me/us.**
7. As required by the terms and conditions of tender an amount of **Rs.14000** is paid by me/us as Earnest Money Deposit (E.M.D.) through online payment in favor of Dr. B.S. Konkan Krishi Vidyapeeth, Dapoli.
8. I/We agree to undertake the **Construction of customized high-rise metal (GI) polyhouse** at location of office mentioned in the final order and as per the specifications of the final order (i.e. as given in Appendix-II) within period of **two months** from the date of firm order.
9. As rates are valid for three months. I/We also agree to undertake the **Construction of customized high-rise metal (GI) polyhouse** in full or in part to other offices of Dr. B.S. Konkan Krishi Vidyapeeth, Dapoli spread over Konkan region under same terms and conditions against the supply orders up to the period of **three months from the date of execution of Agreement/ Warranty Bond.**

10. As per the terms and conditions Appendix - I (Part-I), I/We are submitting our offer in two envelopes. In envelope one (T1), it contains documents as per the condition at Sr. No. 10 of part-I. In envelope two (C1), it includes rates quoted by me/us strictly in the format given in Appendix - II
11. I/We also agree that University has full rights to open/consider the envelope C1 if and only if University is satisfied with information contains in envelope T1. The decision of the University regarding this will be final and will be binding on me/us.
12. I/We hereby declare that the entries made in this tender form, i.e. in Appendix - II are binding for me/us. I/We shall be bound by the Act to my/our authorized representative duly constituted Attorney Shri. _____ signature is appended hereto in the place specified for the purpose and of any other person who in future may be appointed by me/us in his place to carry on the business of this concern/agency/firm. The intimation of such change will be given to The Associate Dean, College of Agricultural Engineering and Technology, Dr. B.S. Konkan Krishi Vidyapeeth, Dapoli.
13. I/We hereby take the responsibility of **commissioning and maintaining the constructed polyhouses for their satisfactory performance at their location(s) free of cost in the warranty period (One year complete warranty on polyhouse frame, all joints, curtain rolling systems and inside shade net sliding system)**. I/We hereby also take the responsibility to provide the services (may be paid) for at least 5 years after expiry of warranty periods.

The following documents duly filled in and signed, are enclosed herewith. The Part-I of Appendix - I being the terms and conditions is retained by me/us for my/our information and record.

Yours faithfully,

Signature of the Supplier

Place: _____
Date: _____

Capacity in which signing: _____

Name and Address of the firm/supplier: _____

Registration No. of the Supplier: _____

List of Documents attached:

1. Part-II of Appendix - I.
2. Registration Certificate of a firm / company.
3. Certificate of manufacturer (self signed declaration on company's letter head) of polyhouses.
4. GST certificate / number.
5. Last three years (2019-20, 2018-19 & 2017-18) income tax return certificates for old firm / company. In case of new firm, last one year (2019-20) income tax return certificate is **must**.
6. PAN card of the proprietor / company.
7. Certificate of previous works / client's list (self signed on company's letter head).
8. Appendix - II. (**In envelope C1 only**).

Signature _____

Signature of constituted
Attorney / authorized representative

Name and Address _____



**COLLEGE OF AGRICULTURAL ENGINEERING AND TECHNOLOGY,
DR. BALASAHEB SAWANT KONKAN KRISHI VIDYAPEETH**

Dapoli 415 712, Dist. Ratnagiri (MAHARASHTRA)

Phone No. (02358) 282414; Fax. (02358) 282414

Email: aicrp.petdapoli@gmail.com



APPENDIX – I (PART I)

Terms and conditions of tender for Construction of customized high-rise metal (GI) polyhouse for research purposes.

1. Sealed Tenders are invited from registered manufacturers for **Construction of customized high-rise metal (GI) polyhouse for research purposes** as per the specifications mentioned in **Appendix-II (Appendix III along with figures 1 and 2)** on or before the last date of **16/03/2021 (up to 11 pm)**. Tender received late will not be considered. The tenders are invited only by e-tendering system. The details are available at maharashtraetenders.in OR at adf.maharashtra.etenders.in/common/home.asp
2. The rates both in words and figures without any corrections or over writing should be quoted in Appendix – II. Any overwriting or rewriting should be duly countersigned. In case of any ambiguity (i.e. if the rates in words and figures do not match / only rate either in words or figures are written / rates not written) the tender will not be considered and will be rejected.
3. **The intending manufacturer shall also have to mention the all work details (Construction of customized high-rise metal (GI) polyhouse for research purposes) for which the rates are quoted. In the absence of the above details, work offered may not be considered.**
4. University will accept the tender for specifications mentioned in the prescribed format (**Appendix – II**) only from registered manufacturer. The decision of the University regarding this will be final and shall be binding on the tenderer.
5. Tenderer will have to complete work as mentioned in the specification and meet the quality standards and name of the manufacturer / company if mentioned in the specifications.
6. **The University reserves the right to accept or reject the work mentioned in the specification other than the above.**
7. Tenderer may enclose published report of comparative study of his quoted items, which will give additional weightage to his quoted price.
8. **The tenderer should quote the rates only in Appendix II of the tender floated on website by this office and not on any other form.**
9. The tenderer should submit his offer in two separate envelopes
10. The tenderer should provide the following documents in **Envelope T1** with superscription i.e. "**Tender for Construction of customized high-rise metal (GI) polyhouse for research purposes**".
 1. Part-II of Appendix - I
 2. Registration Certificate of a firm / company.
 3. Certificate of manufacturer (Self signed declaration on company's letter head) of polyhouses.
 4. GST certificate / number.
 5. Last three years (2019-20, 2018-19 & 2017-18) income tax return certificates for old firm /

company are **must**. In case of new firm, last one year (2019-20) income tax return certificate is **must**.

6. PAN card of the proprietor / company.

7. Certificate of previous works / client's list (self signed on company's letter head).

11. The tenderer should provide rates quoted only in standard format (i.e. Appendix II only) in **Envelope C1** with superscription i.e. "**Tender for Construction of customized high-rise metal (GI) polyhouse for research purposes**". This envelope should clearly state name of the work from Appendix –II for which rates are quoted by the tenderer.
12. **The intending manufacturer should quote the rates inclusive of all taxes, transportation, material, erection, testing etc. (i.e. everything on turn key basis)**. No any extra payment will be made besides quoted rates. **The work will have to be completed as per the specification within two months or as per the last date mentioned in final work order.**
13. University will reserve full rights to open/consider the second envelop if and only if University is satisfied with the information contained in envelope T1. The decision of the University regarding this will be final and shall be binding on tenderer.
14. **The manufacturer will have to construct in full and not in part of the articles as mentioned in Appendix - II** to this University and any other Research Stations of University located anywhere in Konkan region till the date of Validity of rates.
15. **If the mentioned work are not completed within stipulated time limits**, deduction @ 1% of the total cost order value per week for extra time taken will be charged from the bill. However, Associate Dean, College of Agricultural Engineering and Technology, Dr. B. S. Konkan Krishi Vidyapeeth, Dapoli may condone/relax the penalty and may grant extension up to the time limit as deem fit by him, provided the tenderer applies and satisfies about genuineness of the reasons for delay in supply of articles.
16. The tenderer shall have to deposit Earnest Money Deposit (E.M.D.) and tender cost online in the account of the university. **The tender without EMD and tender form cost will not be considered at all**. The amount of the EMD will be refunded online in case of unsuccessful tenderer. **In case of successful tenderer, it will deemed as partial payment towards 3 % of Security Deposit and adjusted accordingly.**
17. The Specimen of "Agreement / Warranty Bond" will be provided along with letter of acceptance to the tenderer whose rates are accepted by the University. The tenderer shall have to execute an agreement in the prescribed form on Stamp paper costing **Rs. 100/-** which should be submitted to this Office within specified time. The agreement received under seal and signature of the tenderer will become legal agreement between the tenderer and the undersigned, which will be binding on the tenderer.
18. If the successful tenderer fails to comply with the **work order** within the specified period of **two months** (from the date of order) or only part supply is made, the Associate Dean, College of Agricultural Engineering and Technology, Dr. B. S. Konkan Krishi Vidyapeeth, Dapoli or respective authority or any officer authorized by him/them, will arrange for the alternative arrangement through **any other manufacturer, cost and expenses** of the said tenderer, who shall have to bear and pay all additional expenditure incurred by the University in that behalf.
19. Successful tenderer will have to furnish security deposit to the extent of 3 % of the rate quoted by the tenderer. This may be deducted from the bill payment or may be asked in the form of DD in the name of "Comptroller, DBSKKV Dapoli. EMD will be adjusted towards this 3 % security deposit. This amount will be held with the University for the warranty period (**i.e. for One year complete warranty on polyhouse frame, all joints, curtain rolling systems and inside shade net sliding system**) and refunded, in normal case, to the tenderer after the warranty period.
20. The amount of Security deposit without any interest there will be returned to the tenderer after **1 year (One year complete warranty on polyhouse frame, all joints, curtain rolling systems and inside shade net**

- sliding system)** or the expiry of the warranty period whichever is later from the date of supply, subject to the surrender of money Receipt in original to this office.
21. On acceptance of the rates as per the approved tender and after completing necessary official formalities, the tenderer will be informed about the acceptance of the tender. The **work** order will be placed by the Associate Dean, College of Agricultural Engineering and Technology, Dr. B.S.Konkan Krishi Vidyapeeth, Dapoli.
 22. The tender submitted on or before the last date will be final and be binding on tenderer and the tenderer shall not be able to withdraw it after the final date.
 23. The Associate Dean, College of Agricultural Engineering and Technology, Dr. B.S.Konkan Krishi Vidyapeeth, Dapoli also reserves the right to obtain the articles/instruments by negotiations with one or more tenderers, if in the case, the rates, quality, specification or other terms and conditions etc. of a tenderer are not found suitable, to this University.
 24. The undersigned also reserves the right to accept or reject the supplies in full or in part which do not strictly stick up to the specifications or to accept the material/articles supplied with slight variations in specifications or with a condition that the rates accepted shall be reduced at such rates as the competent authority of the University may deem fit, looking to the variations and that such rates shall be binding on the tenderer.
 25. University reserves the right to accept or reject - higher version of work etc. under the same terms and conditions and same price quoted by tenderer in Appendix - II.
 26. In case of successful tenderer, the University for Fulfillment of terms and conditions of tender shall retain the amount of Security Deposit (S.D.) deposited by him. The University will not make any payment towards interest on such deposits.
 27. The credit bill should be presented in triplicate in the name of respective authority as quoted in final **work** order is made. For any delay in payment, interest or any other kind of compensation, the University will not make extra payment, etc. This contract will be governed as per terms and conditions mentioned above, Agreement made and the provisions contained in M.A.U. Accounts Code, 1991. Delay in **work completion** within the prescribed time limit or the extended time limit, work not up to the standard specification, and performance or non-observance or non-acceptance of these terms and conditions by the tenderer, shall constitute breach of contract and the security deposit or any other deposit of the tenderer shall be forfeited by this office besides other actions of reduction in bills of supplies and/or other legal actions and finally the decision of the University shall be binding on the tenderer.

Place: Dapoli

Date: 5 MAR 2021

O/C

 Associate Dean
 College of Agricultural Engineering and
 Technology, DBSKKV Dapoli.

Enclosures: 1) Appendix – I (Part – II).

2) Appendix – II (Appendix III along with figures 1 and 2)

APPENDIX - I**Part – II****Undertaking**

{to be given by the tenderer for **Construction of customized high-rise metal (GI) polyhouse for research purposes**}

Whereas, Associate Dean, College of Agricultural Engineering and Technology, Dr. Balasaheb Sawant Konkan Krishi Vidyapeeth, Dapoli has called for tenders for supplies as per the enclosed Appendix - II.

I/We hereby offer our tender at the rates given in the enclosed Appendix-II, duly filled in and signed by me/us and hereby also affix my/our signature (s) below this tender voluntarily and full acceptance of all the terms and conditions of this tender, which shall be the agreement between the above tender calling authority and myself/we.

Encl.: Appendix – II

Signature of the tenderer: _____

Name of the tenderer: _____

Capacity in which signing: _____

Full address of the tenderer : _____

With seal/stamp: _____

Place:

Date:



**COLLEGE OF AGRICULTURAL ENGINEERING AND TECHNOLOGY,
DR. BALASAHEB SAWANT KONKAN KRISHI VIDYAPEETH**

Dapoli 415712, Dist. Ratnagiri (MAHARASHTRA)

Phone No. (02358) 282414; Fax. (02358) 282414

Email: aicrp.petdapoli@gmail.com



APPENDIX-II

Particulars	Quantity	Rate per Unit (Rs.) In figures (and in words).
<p>Construction of customized High Rise Naturally Ventilated GI Polyhouse for Research Purposes. Construction charges (on turn key basis) for construction of naturally ventilated high-rise GI polyhouse on the experimental field of AICRP-PEASEM Dapoli Centre. Polyhouse Size = 23 m x 28 m, gutter height = 4.57 m and central column height = 7 m. The charges should be quoted for the specifications detailed in Appendix-III and figures 1 and 2.</p> <p>The construction charges should include: 1) All taxes, transportation, material, erection, testing etc. i.e. everything on turn key basis; 2) For the place of construction: AICRP-PEASEM Research Field, Central Campus, DBSKKV Dapoli, 3) This office will arrange for water and electricity facility at the polyhouse site, so the quoted price should exclude water and electricity charges, and 3) No extra payment will be made for this work over and above the successful tender price in any case and on any ground.</p> <p>(Important note: Specifications as worded and directed by the concerned Officer In charge / Engineer. The detailed specifications are tabulated in Appendix III along with figures 1 and 2 showing all spatial details. In case of any missing attributes / specifications and any improvements required in the design for the betterment of the design and within the scope of the dimensions (23 m x 28 m), the decision of the Associate Dean, CAET Dapoli on the matter will be final and binding on the manufacturer / successful tenderer).</p>	1 (one unit)	

(Seal & Signature of manufacturer)

APPENDIX III

Detailed specifications for customized high rise naturally ventilated GI polyhouse for research purposes.

(Note: The structure is designed conservatively to resist 140 Km/h wind speed. The below given structural specifications of the GI pipes are the minimum dimensions required. Tenderer can increase the diameter and thicknesses of the GI pipes, but final decision of the tender will be taken on the basis of lowest quote. The successful tenderer / the manufacturer is not allowed to reduce the diameters and thicknesses of the GI pipes given in this design in any case.

Sr. No.	Member names / particulars	Size of GI pipes used for the member	No of members
Part A: Structural details (GI pipe diameter and thickness).			
1.	All side columns (outside)	OD 88.9 mm and 4 mm thick; length = 4.57 m	16
2.	Gable end middle short columns (outside)	OD 101.6 mm and 4 mm thick; length = 4.57 m	2
3.	Gable end tall columns (outside)	OD 101.6 mm and 4 mm thick; length = 7 m	4
4.	All other tall columns (inside)	OD 76.1 mm and 2 mm thick; length = 7 m	12
5.	All other short columns (inside)	OD 76.1 mm and 2 mm thick; length = 4.57 m	6
6.	Bottom chords (Small)	OD 60.3 mm and 2 mm thick; length = 5.5 m	16
7.	Bottom chords (Long)	OD 60.3 mm and 2 mm thick; length = 6 m	16
8.	Rafters (short)	OD 42.4 mm and 2 mm thick; length = 6.44 m (Radius of curvature = 10 m)	16
9.	Rafters (Long)	OD 42.4 mm and 2 mm thick; length = 6.50 m (Radius of curvature = 10 m)	16
10.	End grits (short)	OD 42.4 mm and 2 mm thick; length = 5.5 m	4
11.	End grits (long)	OD 42.4 mm and 2 mm thick; length = 6 m	4
12.	Side grits	OD 33.7 mm and 2 mm thick; length = 4 m	14
13.	Bottom purlins (include gutter purlins)	OD 42.4 mm and 2 mm thick; length = 4 m	28
14.	Middle purlins (with long rafter)	OD 42.4 mm and 2 mm thick; length = 4 m	14
15.	Middle purlins (with short rafter)	OD 33.7 mm and 2 mm thick; length = 4 m	14
16.	Top purlins (with long rafter)	OD 42.4 mm and 2 mm thick; length = 4 m	14
17.	Top purlins (with short rafter)	OD 33.7 mm and 2 mm thick; length = 4 m	14
18.	Gutter level purlins (inside the polyhouse) with tall columns only	Connected to tall columns on boundary: OD 48.3 mm and 2 mm thick; length = 4 m Connected to other tall columns: OD 42.4 mm and 2 mm thick; length = 4 m	4 10
19.	End bracings (bottom chord level)	OD 60.3 mm and 2 mm thick; length = 4.85 m	4
20.	End bracings (rafter level)	OD 42.4 mm and 2 mm thick; length = 4.13 m	4
21.	Inclined supports for top end	OD 21.3 mm and 2 mm thick; length = 0.61 m	16

	of long rafter		
22.	Foundation pipes	For all columns on side walls: OD 76.1 mm and 4.5 mm thick; length = 1.6 m For outer columns on end walls: OD 88.9 mm and 4.8 mm thick; length = 1.6 m For all remaining columns: OD 60.3 mm and 3.6 mm thick; length = 1.6 m	16 6 18
23.	Truss members	With long rafters: OD 33.7 mm and 2 mm thick; length = 2.60 m With short rafters: OD 33.7 mm and 2 mm thick; length = 2.54 m With columns: OD 33.7 mm and 2 mm thick; length = 2.05 m	16 16 32
24.	Sag rods for grits on end walls	OD 21.3 mm and 2 mm thick; length = 1 m	8
25.	<p><u>Important things to note:</u></p> <p>a) All GI pipes should have minimum zinc coating as per the IS 4736:1986. Similarly, all nut bolts, brackets, clamps, L sections, profiles-springs and other accessories should have zinc coating as per the industry standard.</p> <p>b) All the GI pipes used for the polyhouse should be single piece members / joints not allowed, except for tall columns (7 m).</p> <p>c) In case of all tall columns (7 m height), if 7 m pipes are not available in the market, telescopic joints allowed at 6m height or above. Inside telescopic pipes used (having diameter one step down size) for the joints should be at least 60 cm in lengths (thickness at least 3 mm or above) and must connected with at least four nut-bolts / similar best method. Also, for all connector pipe pieces (i.e. pieces connected above the base pipes), outside diameter should be same as the base pipe but thickness of connector pipes may be kept as 2 mm irrespective of base pipe thickness. But base pipes (at least 6 m in lengths) <u>must</u> be as per the specifications given in above table.</p> <p>d) For any Missing Attributes / Specifications: In case of any missing or not given specification, the decision of the Associate Dean, College of Agricultural Engineering and Technology (CAET), Dapoli will be final and binding on the manufacturer / successful tenderer.</p>		

Part B: Details about other greenhouse systems, accessories, shed nets and cover films.

1.	<u>Foundations:</u> Telescopic type, foundation pipe 0.8 m below and 0.8 m above the ground, 1:4:8 concrete, individual pit size 0.45 m x 0.45 m x 0.80 m; hold fast rod size Φ 10 mm and 30 cm long each, at least two nut-bolts for each connection between foundation pipe and column pipe. Fairly level and with firm / non-disturbed soil strata (soil type: laterite) will be given to the contractor for construction of the polyhouse.
2.	<u>Skirting Film:</u> Fixed all along the perimeter, skirting film above ground height is 1.25m, plastic film make Ginegar or other standard, white color, width of film is 2m (with 1.25 m above ground level-GL), film well grounded (about 30 to 40 cm) into the soil, top side of the skirting film is attached to columns using appropriate size GI wire (to avoid sagging) and screws.
3.	<u>Curtains:</u> Total four numbers (two sides walls + two end walls), side and end curtains net width are 2.32 m each, all curtains should have at least 15 cm net overlap over the skirting film, GI rolling pipes used for curtains should be 3/4 th inch (nominal bore size) in diameter and 2 mm thick. All four curtains should be provided with appropriate manual rolling facility (universal joints and (at least) same size -3/4 th inch GI pipe handles). Appropriate size hooks (four numbers) be provided to avoid curtain handle movements when the curtains are fully or partially open. Also, appropriate size (GI pipe / GI wire – with plastic coating only) restraints be provided to avoid curtain movements when curtains are fully closed.

4.	<u>Vent Screenings:</u> Four bottom (two each with side and end walls) and two top vents should be screened with 25 to 35 % white shed net, type: tape x tape (shed net Make: Agrocare India or similar, but must be approved by the engineer before use).
5.	<u>Inside Shad Net System:</u> The inside shed system should cover entire inside area (23 m x 28 m). The shading screens will open-close along longer side (i.e. 28 m). This system should be installed at gutter height (i.e. 4.57 m) with the help of primary GI wires (running just below the gutter, along the width side, total 8 numbers, size: 12 gauge or lower) and secondary / support wires (@ every 1.5 m interval, running parallel to length, size: 18 gauge or lower). But two secondary wires at ends with the sliding curtain rings should be of size 12 gauge or lower. Minimum standard five number of rope-pulley systems (two at ends + 3 equally spaced) should be installed for easy opening and closing of the inside shed net. The inside shading net should be 35 to 50 %, white color, type: tape x tape (shed net Make: Agrocare India or similar, but must be approved by the engineer before use).
6.	<u>Cover Film:</u> As required, 200 micron, make: Ginegar Drip Lock S Cool (C-855), color: white, 87 % light transmission and 77 % light diffusion.
7.	<u>Gutter System:</u> The gutter will run along the length, material galvanized iron, thickness: at least 1 mm, width: 50 cm, standard slope be given to the gutter for safe disposal of the water, gutter should project at least 1 m outside the greenhouse end. Two <u>separate</u> support purlins (i.e. no continuation of gutter purlins) of appropriate size be used for this extension and the outside/discharging end of the gutter be fixed / supported (using customized section) on appropriate size column grounded using 1:4:8 concrete. Also, all along the polyhouse perimeter, water draining channel (rectangular in shape, width at least 20 cm and depth at least 30 cm) be provided for safe disposal of the water.
8.	<u>All Joints:</u> Standard using GI brackets and clamps and GI nut bolts of appropriate sizes. <u>All</u> the bottom chords should be fixed with galvanized L brackets (standard). There should at least two L brackets and four nut-bolts be used for each bottom chord. All the nut-bolts used for all joints must be GI only.
9.	<u>Length / use of Film Locking System:</u> The standard good quality GI profiles and springs be used for this polyhouse. The profile spring locking system should be fixed as normal standard i.e. all along the perimeter of all roofs and walls. But the special requirements listed here must be followed while deciding the length of the profiles and springs and their actual use. Special requirements: 1) All the springs should be used / fixed into the profiles by using cushioning strips (i.e. one more polyethene strip of appropriate width should be used between springs and the cover film), 2) Profile-spring be fitted on both grits on the side walls, 3) This is for the gable ends only: profile be fitted on end grits and also, vertical profiles must run on all columns from top end of the columns to the grits, 4) Two lines of (additional) profiles-springs must be fitted on 3 rd and 6 th trusses/bays. These lines will follow the path: Skirting film- wall portion (except curtain part)-all four roof slopes - other side wall portion (except curtain part) - other side skirting film. For all the profiles, good quality self-driven screws be used for attaching profiles to the GI pipes. The spacings for the self-driven screws should not be more than 80 cm in any case.
10.	<u>Doors:</u> Two numbers (one at front end and other at back end), standard /customized doors, size of each door: 1 m x 2 m, with all required door frame members, hinges, nut bolts, latches, screws, etc. The bottom end of the door should be at height of 15 cm from ground level and the gap should be appropriately closed using polyethylene film.
11.	<u>For any Missing Attribute / Specifications:</u> In case of any missing or not given specification, the decision of the Associate Dean, College of Agricultural Engineering and Technology (CAET), Dapoli will be final and binding on the successful tenderer.

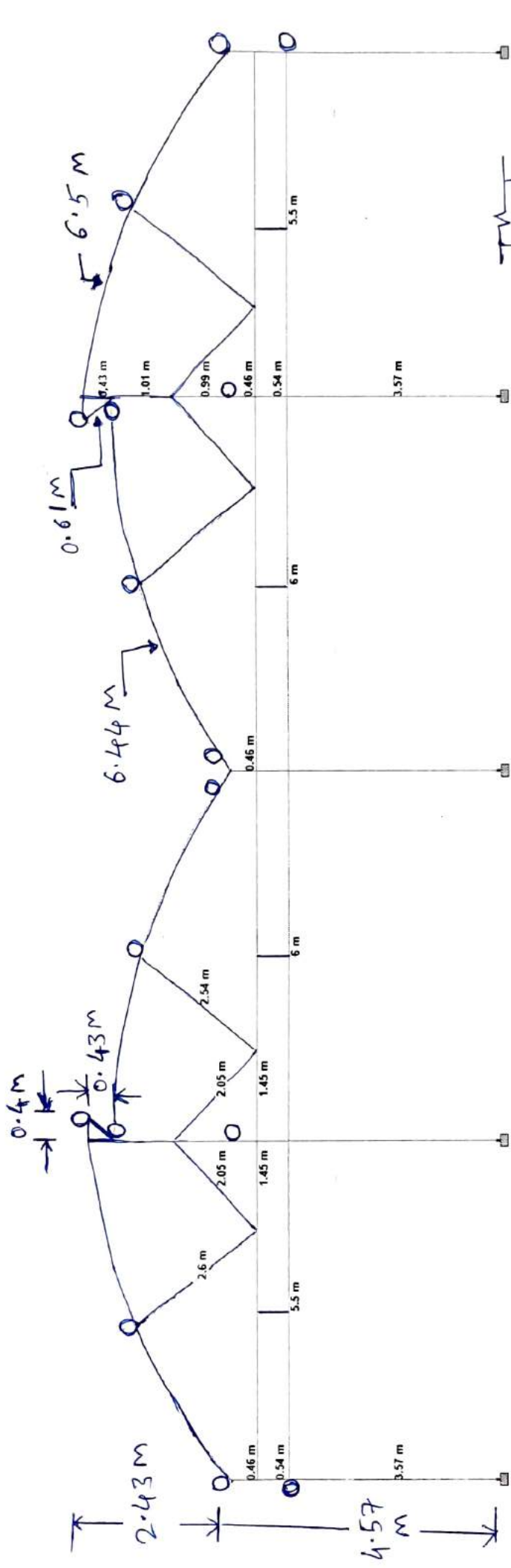

○ → Indicates pyriins.

Fig. 1 Cross Section of the polyhouse.

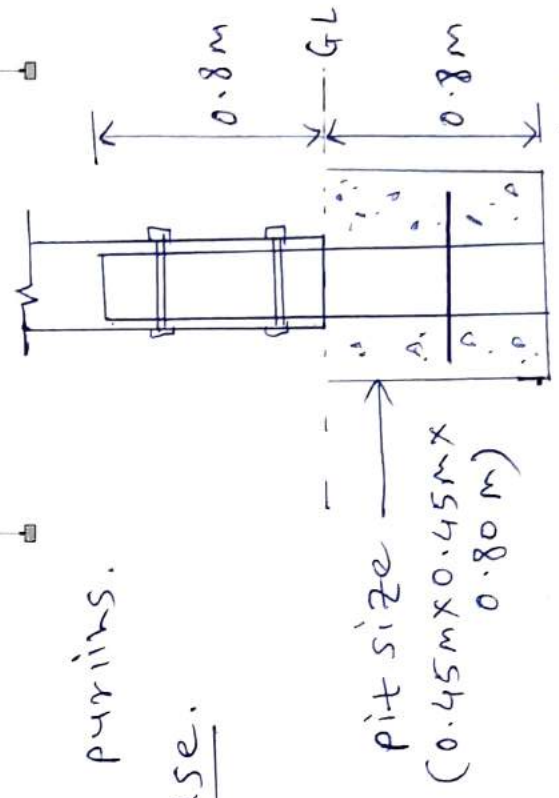

Pit size
(0.45 m x 0.45 m x 0.80 m)

Foundation details

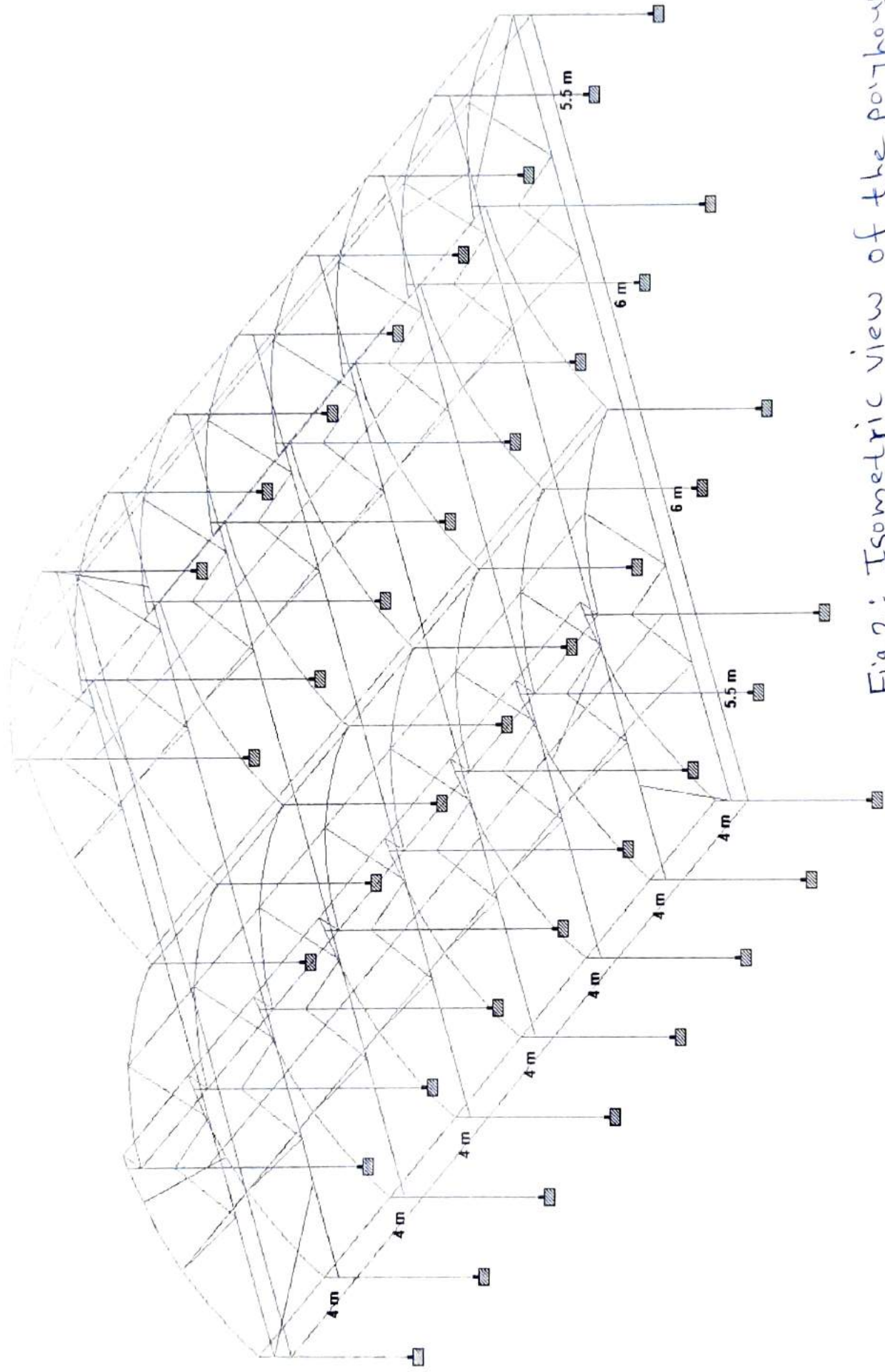

Fig.2: Isometric view of the porthouse.